

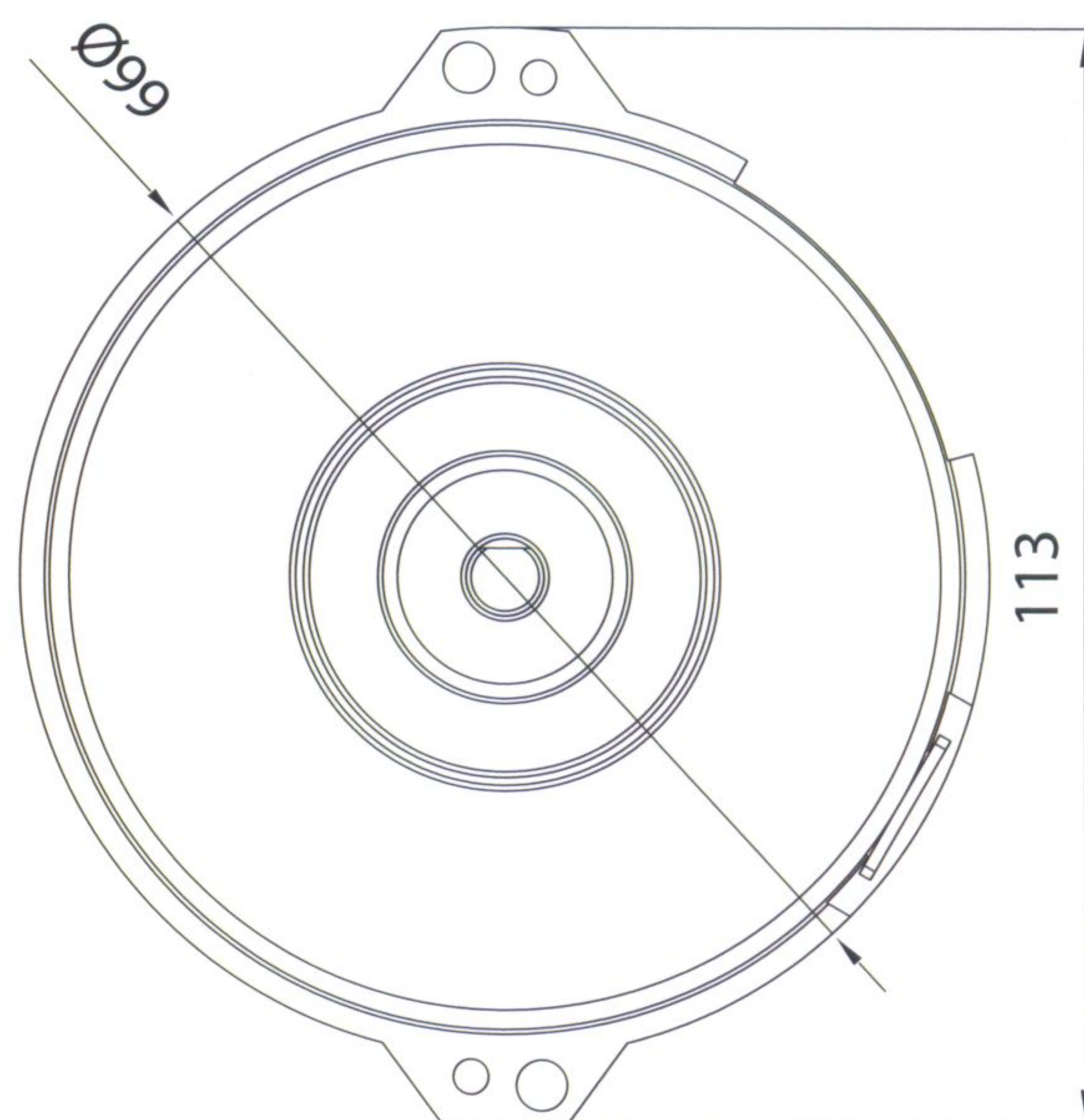

▶▶▶ **JGB02**

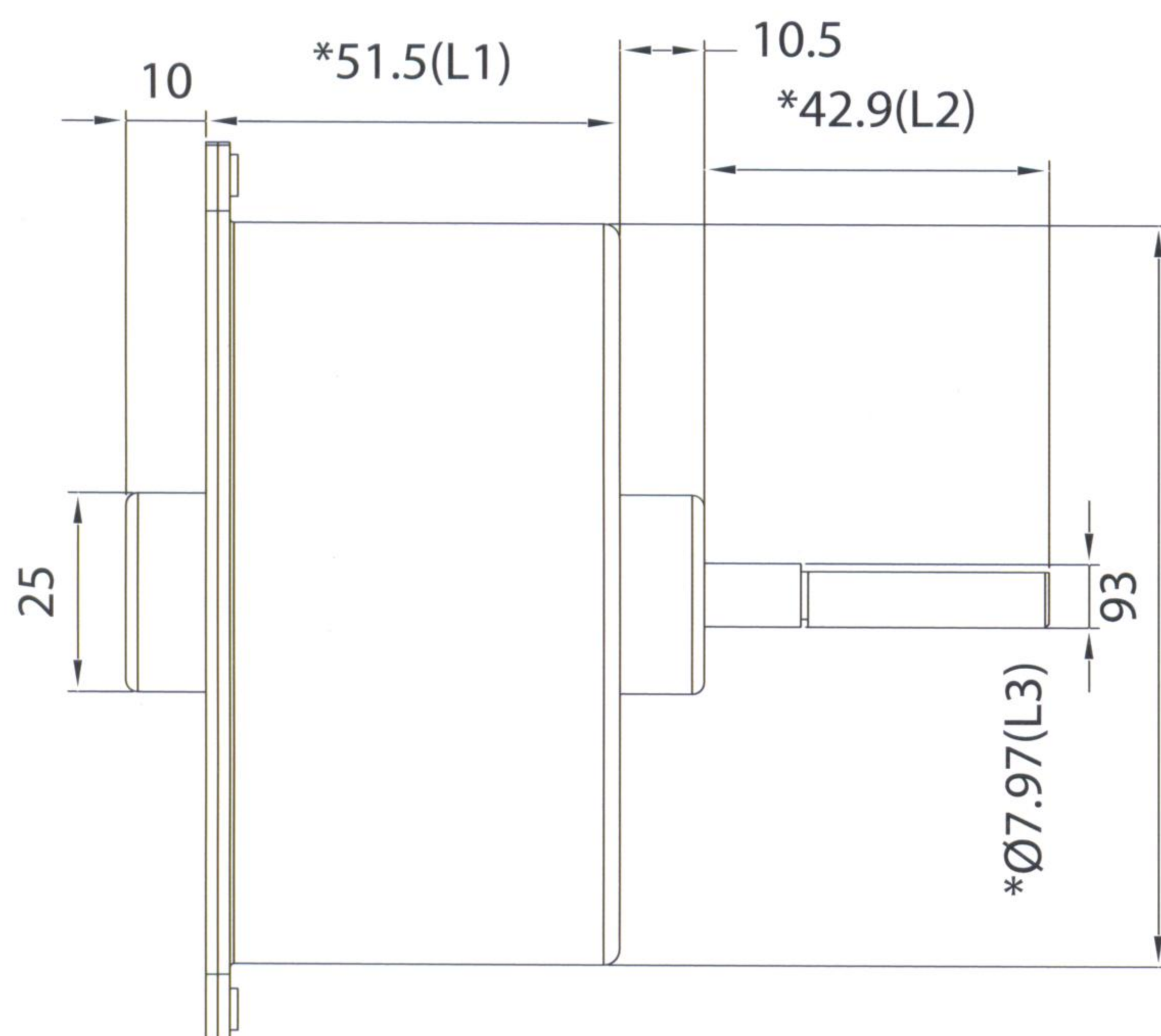

Remark :  
Dimension L1 , L2 , L3 is flexible.

## SPECIFICATIONS

VOLTAGE	RATING CURRENT	RATING TORQUE	RATING SPEED
36 V	1.5 A	2.9 KG-CM	1450 RPM

### FEATURE

1. Voltage : All for AC/DC
2. Current, Torque and Speed depends on customer requirement.
3. Control mode : Speed control, torque control, .....etc.
4. Control interface : SPI, UART, PWM, .....etc.